

Architectural Canopy

ASC's architectural canopies offer a durable and attractive solution to enhance your building's exterior shading system. Excellent for commercial and industrial applications, architectural canopies provide shade and cover from sun, snow, and rain. Whether it's for a storefront, drive-through window, outside patio, or building entrance, our team can assist with helping you choose the best option for your project!

Fully welded and built with high-strength extruded aluminum alloy, our architectural canopies are light-weight and built to withstand the elements. We offer a wide selection of standard and non-standard paint and powder coat finishes to ensure this product has a high-quality and long-lasting finish to meet your project's specific needs.

Depending on your project's requirements, our architectural canopies can be cantilevered or mounted with adjustable hanger arms. Both mounting options use the building's existing structural support system and help distribute wind and snow loads over large areas.

- Gutter Fascia
 - 8", 10", or 12"
- Roof Pans
 - 3" x 6"
 - 2" x 8"
- 4" Structural Channel
- Mounting Options
 - Adjustable Hanger Arms
 - Cantilever
- Heavy-Duty Mounting Options
- Draining Scuppers
- LED Soffit Lights
- Powder Coat or Paint
 - White, Black, or Bronze
 - Other colors on request
- Custom Specs and Configurations Available
- Made in the USA

With Hanger Arms

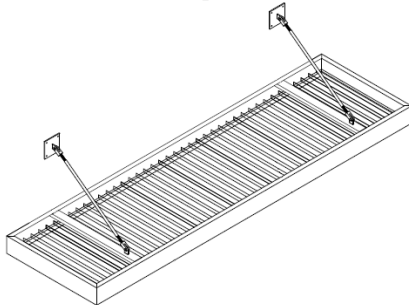

Cantilevered

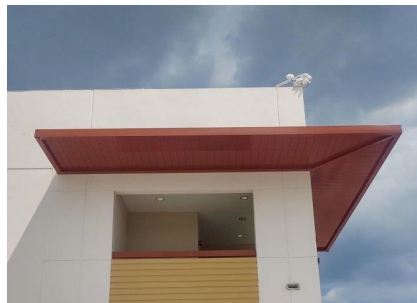
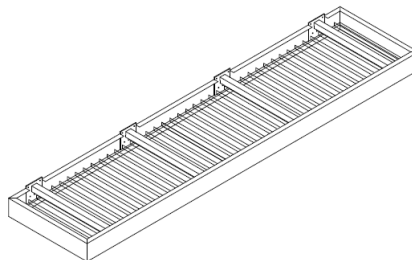

Locations:

ASC IN (Headquarters)

340 Hoosier Dr.
Angola, IN 46703
(260) 665-1521

ASC FL

1710 Industrial Dr., Suite 5
Edgewater, FL 32132